



## KEY LARGO VOLUNTEER FIRE DEPARTMENT, INC.

*Key Largo Volunteer Fire  
Department, Inc. is committed to  
providing the highest level of fire  
and rescue services possible  
through community involvement,  
education and prevention. Our  
team of friendly and dedicated  
professionals will strive for  
excellence to serve our community  
in paradise*

**ANNUAL REPORT**

**2013**



Key Largo Fire Department, INC.

ANNUAL REPORT 2013

TABLE OF CONTENTS

<b>INTRODUCTION, LEGAL DESCRIPTION</b>	<b>PAGE 1</b>
<b>LEGAL BOUNDARIES OF SERVICE AREA, MISSION STATEMENT, DEPT. CHARACTERISTICS,</b>	<b>PAGE 2</b>
<b>COMMUNITY DEMOGRAPHICS, CHALLENGES/VULNERABILITIES</b>	<b>PAGE 3</b>
<b>RESPONSE TO CHALLENGES/VULNERABILITIES EMERGENCY INCIDENT/CALL VOLUME 2011 &amp; 2012</b>	<b>PAGE 3-4</b>
<b>RESPONSE TO CHALLENGES/VULNERABILITIES – Grants and Improving ISO RATING</b>	<b>PAGE 4-5</b>
<b>FIRE PREVENTION</b>	<b>PAGE 5</b>
<b>WATER EMERGENCY TEAM, NEW FIREFIGHTING APPARATUS, FIRE CHIEF</b>	<b>PAGE 5</b>
<b>TRAINING</b>	<b>PAGE 6</b>
<b>UPPER KEYS HONOR GUARD</b>	<b>PAGE 6</b>
<b>DONATION DRIVE</b>	<b>PAGE 6</b>
<b>RETENTION AND RECRUITMENT</b>	<b>PAGE 6-7</b>
<b>HEALTH AND WELLNESS</b>	<b>PAGE 7</b>
<b>NIMS COMPLIANCE</b>	<b>PAGE 7</b>
<b>LOOKING FORWARD</b>	<b>PAGE 8</b>
<b>ATTACHMENTS:</b>	<b>PAGE 9</b>
<b>ORGANIZATIONAL CHART AND MEMBERSHIP</b>	<b>ATTACH # 1 PAGES 1-3</b>
<b>KEY LARGO FIRE DEPT. NFPA SURVEY 05//28/13-12/31/13</b>	<b>ATTACH. #2</b>
<b>AVERAGE ATTENDANCE AT INCIDENTS</b>	<b>Attach. #3</b>
<b>TOTAL ANNUAL INCIDENTS 6 YEAR HISTORY</b>	<b>Attach. #4 PAGES 1-4</b>
<b>KEY LARGO FIRE RESCUE AND EMS DISTRICT BUDGET – KLVFD FY 2013/2014</b>	<b>BUD. – 2013/14</b>
<b>KEY LARGO VOLUNTEER FIRE DEPARTMENT, INC. CORPORATE FINANCIALS</b>	<b>2013</b>

# KEY LARGO FIRE DEPARTMENT, INC. ANNUAL REPORT 2013

---



## INTRODUCTION

Key Largo Volunteer Fire Department, Inc. (KLVFD) is a newly formed not for profit corporation that consists of approximately 60 volunteer members, and is a combination fire department that also employs 3 full time firefighters; 4 part-time firefighters; and 1 Station Manager. The Department was formed at the end of May, 2013. This transition was primarily a management change – the Department maintains and continues the long history of quality fire service to the Key Largo community and provides 24 hour a day fire rescue services to the residents of Key Largo, an island community of approximately 11,000 yearly residents. The Department continues to operate out of two fire stations. Our North Key Largo Fire Station number 25 is located at 220 Reef Drive at the intersection of U.S. Highway 1/Overseas Highway and State Road 905. Our South Key Largo Fire Station is located at the 99.8 mile marker at the intersection of U.S. Highway 1/Overseas Highway and 1 East Drive.

During the season and on weekends and holidays the population of Key Largo increases dramatically with an influx of tourists and “snow-bird” part time residents and retirees. Visitation in Key Largo is estimated at over 4 million visitors per year. Visitation is year-round due to the subtropical climate of the area and the lure of world class fishing and diving due to the proximity to the largest living coral reef in the U.S. located in nearby Biscayne National Park, it’s crystal clear protected waters, largest man-made reef – sunken U.S.S.

Spiegel Grove, numerous shipwrecks, and its and exotic natural and relaxed atmosphere.

Key Largo is the first key or island of a string of islands off of the southernmost tip of Florida that stretch for 100 linear miles from Key Largo to Key West that make up the Florida Keys, Monroe County, Florida. The population of Monroe County is approximately 73,000 with a visitation count of over 4 million. The island of Key Largo is approximately 27 miles long and consists of approximately 22,000 acres. Key Largo Fire Department’s jurisdiction extends to the near shore waters of the Florida Bay and the Atlantic Ocean and a number of small islands in those waters as well as numerous canals and marinas that are all bordered by resort, residential and boating communities. Homes in the area consist of mobile homes and trailers, live-aboard boats/vessels, homes built prior to quality construction codes, as well as fully code-compliant homes.

Key Largo has a seasonal tropical storm and hurricane season as well as a dry/fire season.

KLVFD operates as the incident command center and emergency operations center and shelter during tropical storms and hurricanes as well as for any hazardous or radiological emergencies that might occur as a result of an accident from the nearby Turkey Point Nuclear Power Plant. To be equipped with the ability to respond to any and all emergencies or activities that might occur during these times via land and sea is imperative.

The responsibility for fire, rescue, and EMS services in the Key Largo district falls under the Key Largo Fire Rescue and EMS Special Independent District formed in 2006. The District has the authority to levy and collect ad valorem taxes for fire, rescue and EMS services

# KEY LARGO FIRE DEPARTMENT, INC. ANNUAL REPORT 2013

---

from the taxpayers of Key Largo. The District has a 5 member Board of Commissioners that operates in the Sunshine and oversees the budget and administration of the Key Largo District.

## LEGAL DESCRIPTION

Monroe County Ordinance 035-1996 states the boundaries for District 6:

*That part of Key Largo from South Bay Harbor Drive and Lobster Lane to the southern boundary of the intersection of the right-of-way County roads 905 and 905A, plus Cross Key.*



## MISSION STATEMENT

*The Key Largo Volunteer Fire Department is committed to providing the highest level of fire and rescue services possible through community involvement, education and prevention. Our team of friendly and dedicated professionals will strive for excellence to serve our community in paradise.*

## DEPARTMENT CHARACTERISTICS

You will see from the organizational chart (Attach. #1) that Key Largo Fire Rescue Department is structured in such a way to allow for the highest level of professional coverage by identifying the positions necessary to accomplish this and ensure proper checks and balances and chain of command. The nature of the mostly volunteer / combination department does not always allow us to fill every position,

but we have identified the necessity and opportunity for each. We have been fortunate that in difficult economic times when budgetary constraints are an ever tightening reality and volunteerism is ever decreasing that we have managed to retain and recruit an impressive number of volunteers. Additionally, we have been creative in identifying our needs for full time uninterrupted coverage and been allowed to meet some of those needs with the addition of full time and part time paid career personnel. The Department continues to meet and exceed State of Florida requirements for certification requirements for paid and volunteer personnel and to ensure that all personnel are well trained and physically fit.

Our combat operations team consists of a volunteer fire chief, chief, volunteer battalion chief for safety and training, and a volunteer water rescue captain, full time paid safety captain, 2 full time paid lieutenants, 1 part time paid lieutenant, 5 volunteer lieutenants, and 2 volunteer engineers. Our station manager handles all management issues and administrative issues and supports both the combat operations and the administrative operations of the department. The combat operations handle all fire rescue activities, with specialties in water rescue and dive rescue, structural firefighting and vehicle extrication; fire prevention and education, pre-fire planning, hydrant inspection, training and health and safety.

Our corporate operations consist of a volunteer corporate president, vice president, volunteer treasurer, volunteer secretary/clerk, legal counsel, 1 full time paid employee as a director, and 3 volunteer directors. The corporation oversees the fire chief of the department and enters into the contract for services with the

# KEY LARGO FIRE DEPARTMENT, INC. ANNUAL REPORT 2013

---

District Board of Commissioners. The Corporate Board of Directors oversees membership and Corporate business matters and operates in compliance with Florida Sunshine Laws.

## **COMMUNITY DEMOGRAPHICS AND CHALLENGES/VULNERABILITIES – Fire Department Response**

### **Demographics**

Key Largo is a small island community that is home for many senior citizens. The U.S. 2010 Census has the population of Key Largo at 10,433. Senior Citizens age 65 years and older comprise 18 percent of the population. Many residents of the area own second homes or are snow-birds that come seasonally and make their residence in another city and state. Most of these individuals are retirees 65 years and older. Children 14 years and under according to the U.S. 2010 Census comprise 13.3 percent of the population. It is important to note that visitation to Key Largo is year-round with the heaviest influx during snow bird season (November through April) and Spring Break Season (March through May). Weekend visitation is extremely high. The local Chamber of Commerce estimates that the annual visitation can easily exceed 4 million per year. Many of these visitors spend their time in our various households/homes in the Keys.

### **Challenges/Vulnerabilities**

Key Largo residents and visitors reside in a variety of different types of homes. Key Largo has 7 trailer communities with approximately 2,800 residents (U.S. 2010 CENSUS); marinas that house live-aboard vessels (approximately 5 communities, with approximately 55 boats and 80-90 residents); and homes that were constructed prior to the development of quality

building codes and “grandfathered” so that they are not required to meet current quality building and fire codes. The vulnerability for fire hazards to exist in these environments is great.

Visitation has doubled in the past 2 years accordingly to recent tourism figures. Approximately 89 percent of visitors whether it be visiting and staying in Key Largo or passing through Key Largo do so via automobile. This would account for the large percentage/number of annual motor vehicle accidents.

## **RESPONSE - INCIDENT STATISTICS**

### **EMERGENCY INCIDENT/CALL VOLUME 2013 FROM 5/28/2013 TO 12/31/2013**

**2013 (5/28/13-12/31/13) Total emergency call volume** for all incidents was **269**. (*Attach. #2*)

**Total fire related incidents** were 18 incidents, or 6.6 percent of the total call volume (269). (*Attach. #2*)

**Motor Vehicle accidents totaled 56** and comprised 20.8 percent of our total call volume in **2013 (5/28/13-12/31/13)** (269).

The Department provided **mutual aid** to neighboring fire Departments **6 times in 2013 (5/28/13-12/31/13)**. (*Attach. #2*)

The number of incidents where we provided **EMS or Medical assistance** totaled **103** or 38.3percent of the total call volume in **2013 (5/28/13-12/31/13)** (269).

### **EMERGENCY INCIDENT RESPONSE 2013 (5/28/2013-12/31/2013)**

# KEY LARGO FIRE DEPARTMENT, INC. ANNUAL REPORT 2013

---

**Average Attendance** at NFIRS (total) incidents (269) in 2013 (5/28/13-12/31/13) was 4.4. (Attach. #3)

## **UNAUTHORIZED/ILLEGAL BURNING 2013 (5/28/2013-12/31/2013)**

The total number of unauthorized and illegal burns in 2013 (5/28/13-12/31/13) totaled 8 or 3 percent of the total call volume (269).

The total number of false alarms for 2013 (5/28/13-12/31/13) totaled 29 or 10.8 percent of the total call volume (269). (Attach. #1)

## **RESPONSE – ADDRESSING CHALLENGES/VULNERABILITIES**

Since the Fire Department and Key Largo Fire Rescue & EMS District passed the open burn ordinance and the false alarm ordinance, we have experienced a decrease in these types of calls.

Key Largo experiences an annual tropical storm and hurricane season that lasts from April until November. The fire department feels it is a large part of their mission and responsibility to ensure that the members and visitors to their community have the opportunity to become educated on what measures to take during such emergencies and what to do when they find themselves in these emergency situations.

### **Grants and Improving ISO Ratings**

The Department just recently applied for a FEMA grant in order to offset our training expenses. Training identified in this grant will be: 1. Driver Operator; 2. Fire Officer I Series; 3. Firefighter I State of Florida Certification Course; and, 4. Firefighter Safety and Survival RIT (Rapid Intervention Team) training.

The Department received a grant which allows the firefighters to provide and install free smoke detectors in all residences requesting this service. This also gives the department the opportunity to provide fire and safety prevention techniques and education to our residents.

Key Largo is the Dive Capital of the World. You are never more than 3 minutes from water when you are in Key Largo. The community consists primarily of businesses and homes that are either directly ocean, bay, canal front, or just adjacent to a water source. We do; however, have some areas in our District that are not close to an available water source. This has adversely affected our ISO rating in the past; however, by obtaining a grant through Fireman's Fund Insurance agency, our Station Manager was able to purchase two Turbo Drafts to aid in getting water to these areas. This has resulted in a great improvement in our ISO ratings for those areas which has directly translated into savings in insurance premiums for our businesses and residents located in those areas.

In 2011 we completed a full ISO review of our Department and operations. Our ISO rating has improved from a 9 to a 5 in over 80 percent of the Key Largo area. Our overall rating is a 5/9.

The department has made a concerted effort with the support of the Key Largo Fire Rescue and EMS District to improve our service and ultimately our ISO rating through the installation of new hydrants, improvement in staffing levels, water supply, training, equipment, and many other components that are considered when an ISO review is conducted. The department currently has 119 hydrants with \$100,000.00 in infrastructure dollars programmed in fiscal year 2013/2014 for

# KEY LARGO FIRE DEPARTMENT, INC. ANNUAL REPORT 2013

---

new hydrant installation. Our firefighters conduct quarterly inspections of these hydrants and the District budgets for the Florida Aqueduct Authority to conduct a full annual inspection and maintenance program on all hydrants.

## **FIRE PREVENTION**

**FIRE PREVENTION** is the "NAME OF THE GAME" as far as Key Largo Firefighters are concerned. The best way to support our Community and provide the highest level of fire rescue services is to continually educate the public on what they can do to PREVENT fires, accidents and injuries due to emergency related incidents. We also continually strive to educate OURSELVES in the latest fire and rescue techniques and strive to ensure that our neighborhoods, businesses, marinas, schools, etc. are the recipients of pre-fire planning and inspection. Education, training and preparation are essential in ensuring that this happens.

We continually like to encourage residents, schools, and businesses to contact us for a free pre-incident inspection and fire prevention session. We regularly conduct pre-fire planning of our local businesses so that we know the layout of the property, where the necessary water sources and hook-ups are located, the type of emergency warning and sprinkler systems they have and where the control panels are located, entrance and egress to the properties, etc. so that we can provide the most efficient and highest quality service in time of need.

We regularly schedule fire prevention education and activities at the local pre-schools and elementary schools during fire prevention week as well as throughout the year as requested.

## **WATER EMERGENCY TEAM**



The community boasts the first and largest man-made reef in the Florida Keys with the sinking of the Spiegel Grove 3 miles off the shores of Key Largo in the Atlantic Ocean. Divers from around the world come to visit the area.

Key Largo is home to one of the most elite special response teams - the **Water Emergency Team (WET)** comprised of local men and women, most of which hold the certification of dive master and rescue diver and work for the local dive business in Key Largo while volunteering their services to the community.

## **NEW FIREFIGHTING APPARATUS**

The Department owes a HUGE THANK YOU to the tax payers of the Key Largo District for their support and tax dollars which has allowed the Department to receive delivery of 3 new fire trucks this fiscal year. The department has replaced their Squad/Rescue Pumper with a new Rescue Pumper and has replaced both their Aerial/Ladder truck and Tanker. (Attach. #4)

The Department has planned a COMMUNITY APPRECIATION OPEN HOUSE to thank the Community and show off the new vehicles in March of 2014.

## **FIRE CHIEF**

**Fire Chief Donald Bock** is a volunteer Fire Chief for the Key Largo Volunteer Fire Department. Chief Bock is also the Chief of the Key Largo Volunteer Ambulance Corps. as well as an Officer and Paramedic for Monroe County Fire Rescue Department.

# KEY LARGO FIRE DEPARTMENT, INC. ANNUAL REPORT 2013

---

## TRAINING

Our Commitment to training continues. The Department boasts 5 state certified fire instructors. In addition to daily training drills with on-duty shift personnel the department conducts training on Thursday evenings. Additionally, a focus in 2013 has been ensuring all personnel are educated in NIMS, Mayday training, and E.V.O.C. We recently sent 2 Firefighters to a "Train the Trainer" E.V.O.C. training course and now have 3 certified E.V.O.C. instructors.

The Department has a comprehensive orientation and training for all new firefighters. This training or "Rookie Book" must be satisfactorily completed by new volunteer firefighters prior to final acceptance with the Department.

## UPPER KEYS HONOR GUARD



Key Largo Volunteers organized the first Upper Keys Honor Guard consisting of Firefighters from the Upper Keys, Key Largo, Tavernier and Islamorada Fire Departments. The Honor Guard is led by its Captain, Montillo (Scott) Desquotte, a volunteer firefighter with our Department.

The members of the Honor Guard regularly train and compete and dedicate their services to their local communities as well as other Departments throughout Florida and the Nation. They are involved in awards banquets, memorial services, local charitable events, conferences, and fund raising activities such as the Fourth of July Florida Honor Guards in Paradise. We hosted a Fourth of July Parade

and celebration with honor guards and pipe and drummers from all over the world.

Our Honor Guard will participate in a similar event on St. Patrick's Day in Delray Beach, FL. and annually participate in the Florida State Fire College's Fallen Firefighter memorial ceremony.

Our District greatly values the positive attention that is brought to the Department and Community through the activities of the Honor Guard and has allocated funds in the 2013/2014 fiscal budget in order to offset some of their expenses.

## DONATION DRIVE

The continued service and dedication of our approximately 60 volunteer and paid firefighters has had a significant impact on our District's ability to keep the taxes in Key Largo the lowest in unincorporated Monroe County.

We could not do it without support from our residents and business owners, however. The new department plans to continue the tradition of sending out an annual donation letter to our taxpayers and are grateful for the continued support and donations from our community.

Our doors are always open to the public. We welcome requests for information, assistance and participation in local events, and of course we welcome anyone interested in volunteering.

## RETENTION AND RECRUITMENT

The Department welcomed 13 new volunteer firefighters with just recently another 8 pending approved memberships (Feb. & Mar. 2014) All of our applicants come to us as fully state certified Firefighter II's and usually have their National EMT and/or Paramedic certification as well.



# KEY LARGO FIRE DEPARTMENT, INC. ANNUAL REPORT 2013

---

Key Largo Fire is fortunate to have so many personnel, both paid and volunteer, who are devoted and dedicated to this department and to the community they serve. It is an exceptional group of people that go above and beyond what is expected of most – and usually do it with a smile on their face.

The Department has implemented a volunteer reimbursement program and training program that have proven to be highly beneficial in attracting volunteers to the Department and in retaining them even after they have accepted paid positions with other Departments. Job opportunity both full time and part time have aided in recruitment and retention as well.

Plans for offering retirement programs (401K) have been recently approved.

Our Department cares about the community it serves and offers support and services that extend beyond the reactive fire and rescue services through fire prevention and education, pre-fire planning, and involvement in community events. We instill a sense of “Community” in our Department. This intrinsic value of belonging and helping one another is probably the largest contributing factor toward retention of volunteers and staff.

## HEALTH AND WELLNESS

The health and wellness of our firefighting personnel is vital. The Department makes the physical fitness and health and wellness of its firefighters a top priority. The Department encourages physical fitness by the use of its donation dollars to create a gymnasium equipped with state-of-the-art exercise equipment. Volunteers are encouraged to use the gym while on shift and paid personnel are

allotted an hour per day to be used exclusively for physical fitness.

The Department conducts annual fit for duty testing and physical ability testing and medical physicals are required prior to employment. All volunteers are required to pass the state of Florida Firefighter physical.

Annual health screenings are required of all personnel. The District budget has provided the funds to cover the cost in full of these comprehensive health screenings that are conducted on the fire department premises.

The Department is a smoke free drug and alcohol free organization with policies governing this.

The Department has also donated to and joined a number of Cancer Awareness and Support groups and has shown their support for breast cancer awareness by “wearing pink” cancer awareness combat shirts.



## NIMS COMPLIANT

NIMS compliance Resolution to comply with the Presidential Directive HSPD-5 was adopted by the KLFR &EMS District in 2008.

The Key Largo Fire Rescue and EMS District is committed to providing the most effective approach to prepare for, respond to, and recover from domestic incidents regardless of the cause, size or complexity and supports a unified approach toward command, training, and management of resources to ensure interoperability and compatibility among Federal, State and local emergency agencies.

## DEPARTMENT BUDGET

# KEY LARGO FIRE DEPARTMENT, INC. ANNUAL REPORT 2013

---

The Department budget for 2013/2014 is attached to this document as ATTACHMENT BUD-2013/2014.

The Department has consistently worked with the District in an effort to reduce budget line items in an effort to keep the tax burden to our residents and businesses as low as possible.

## **CORPORATE FINANCIALS**

The end of the year financials are attached to this document as ATTACHMENT FIN-CORP-2013.

## **LOOKING FORWARD...**

We've come a long way since the inception of this new department on May 28, 2013. We carry with us the tradition and history as well as much of the personnel from the previous Department – essentially 60 years of primarily volunteer service to the Key Largo Community. Today we are still a small town Community when it comes to available resources, but we have become significantly larger when you look at our vulnerabilities and the challenges we face. We continue to provide the highest level of fire and rescue services at the lowest cost in Monroe County. And we are doing this in a rapidly changing municipal and political environment with ever challenging economic realities. Post 911 strengthening of requirements for the Fire Service create new challenges as well. Our challenges may be different than they once were and may be not quite as evident, but they are very real. We have, however, managed to meet these challenges and improve our quality and level of service and will strive to continue the trend through education, communication, teamwork and strategic planning.

*Thank you to the staff and members of the Key Largo Volunteer Fire Department, our District Commissioners and contract staff as well as all of the members and staff of the Key Largo Volunteer Ambulance Corps. A very special thank you to the Community we are privileged to serve.*

**Key Largo Taxpayers**

**Corporate President**

**Corporate Board of Directors**

<b>CORPORATE</b>
President <b>Ronnie Fell</b>
Vice-President <b>Scott Robinson</b>
Corporate Secretary <b>Pamela Johnson</b>
Director <b>Dave Gow</b>
Director <b>Mark Wheaton</b>
Director <b>Eric Fundora</b>
Director <b>Eric Fundora</b>
Treasurer <b>Kenneth Edge</b>

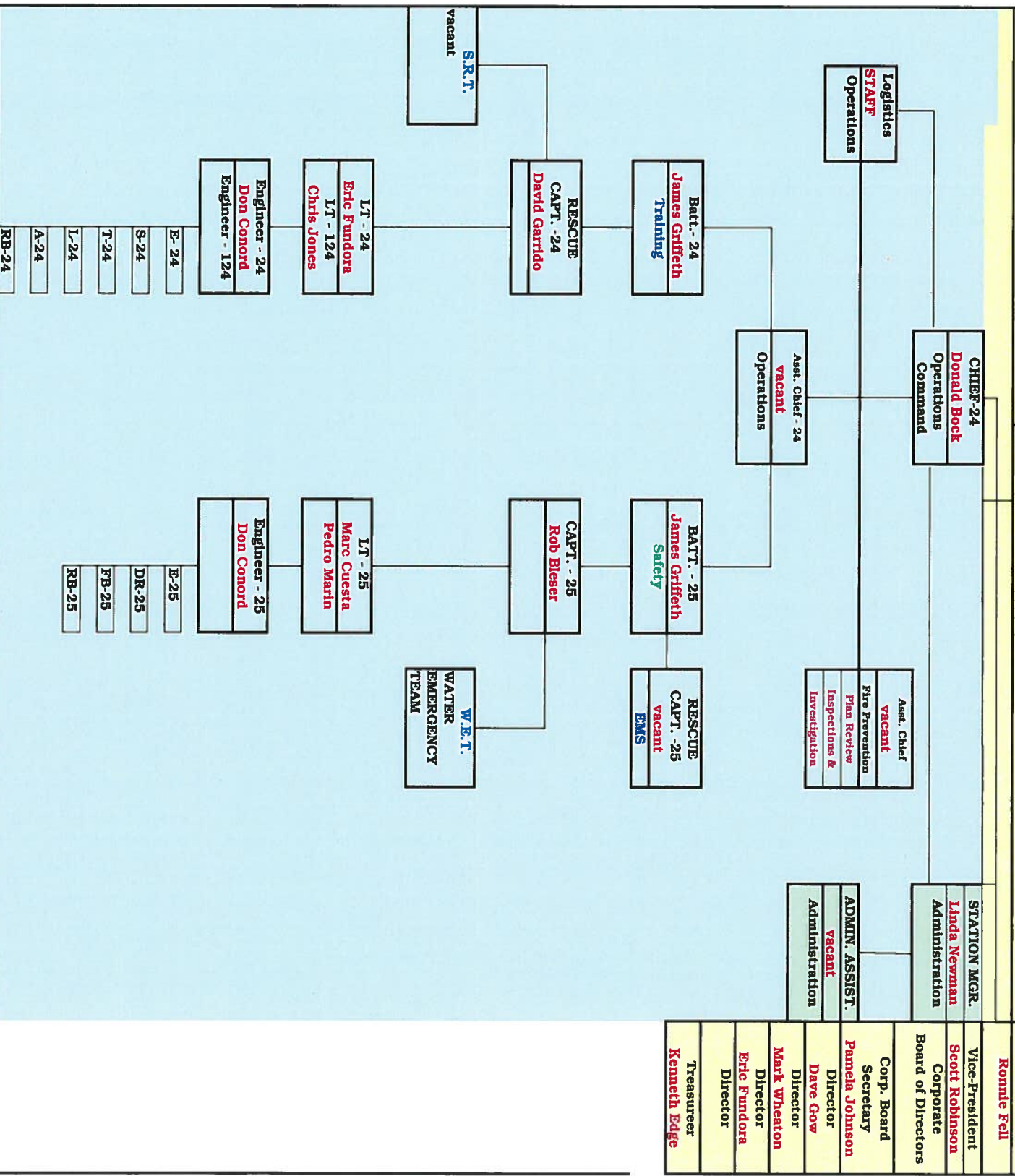

ATTACH. 1

1063

**KEY LARGO VOLUNTEER MEMBERSHIP 2013**

NAME

Arkin, Steve  
Aulet, Arturo  
Barnes, Edwin  
Barnes, Robert  
Blanco, Rodolfo  
Bleser, Rob  
Bock, Don  
Bohl, D/E Andrew  
Calante, Rafael  
Campos, Jorge  
Conord, D/E Don R  
Cuesta, Lt. Marc A  
Desquotte, Scott  
Edge, Kenny  
Fell, Ronnie  
Fernandez, Gabriel  
Fundora, Lieutenant Eric  
Garcia, Alex  
Garcia, Carlos  
Garcia, Fernando  
Garcia, Nelson  
Garcia Jr, Sergio T.  
Garrido, Captain David  
Golling, Markus  
Gonzalez, Arley  
Gonzalez, Luis  
Gonzalez, Michael  
Gow, David  
Griffeth, Battalion Chief James  
Gutierrez, Reynaldo  
Hanna, Joseph  
Harder, Jackie  
Hermann, John  
Herrera, Gehovany  
Jenkins, Engineer Michael T  
Jones, Lieutenant Christopher J  
Lamm, Jeremiah  
Llerena, Jonathan  
Lopez, Casey  
Lopez, Jason  
Marin, Lieutenant Pedro L  
Marte, Melvin  
Martin Jr., Ivan  
Melguizo, Andres  
Mirabella, George

Montero, Brian  
Moreno, Leonardo  
Mosczyński, Paul  
Mumper, Jason  
Navarro, Luis  
Neitzer, Eric  
Newman, Linda E.  
Ogden, Jack  
Paz, Jonathan  
Quinones, Angie  
Reategui, Luigi  
Robinson, Scott  
Roig, Ishmael  
Schalk, Steve  
Sierra, Edward  
Sommers, D/E Charles  
Suarez, Adrian  
Trujillo, Aldo  
Varela, Jonathan  
Vazquez, Luis  
Wheaton, Mark  
Wilson, Al

# Key Largo Fire Dept.

Period: From 05/28/2013 to 12/31/2013

## NFPA Survey Report

FIRE IN STRUCTURES BY FIXED PROPERTY USE (OCCUPANCY) (All in Section A Incident Type 110-129)	Number of Fires	Number of Civilian Fire Casualties. If none, write 0.		Estimated Property Damage from Fire. If no loss, write 0.
		Deaths	Injuries	
1. Private Dwellings (1 or 2 family), Including mobile homes (FPU 410-419)	1	0	0	\$17,500
2. Apartments (3 or more families) FPU 429 or FPU 439)	0	0	0	\$0
3. Hotels and Motels (FPU 449)	1	0	0	\$0
4. All other residential (dormitories, boarding houses, tents, etc.) (FPU 459-499)	0	0	0	\$0
<b>5. TOTAL OTHER RESIDENTIAL FIRES (SHOULD BE SUM OF LINES 1 THROUGH 4)</b>	<b>2</b>	<b>0</b>	<b>0</b>	<b>\$17,500</b>
6. Public Assembly (church, restaurant, clubs, etc.) (FPU 100-199)	0	0	0	\$0
7. Schools and Colleges (FPU 200-299)	0	0	0	\$0
8. Health Care and Penal Institutions (hospitals, nursing homes, prisons, etc.) (FPU 300-399)	0	0	0	\$0
9. Stores and Offices (FPU 500-599)	0	0	0	\$0
10. Industry, Utility, Defense, Laboratories, Manufacturing (FPU 600-799)	0	0	0	\$0
11. Storage in Structures (barns, vehicle storage garages, general storage, etc.) (FPU 800-899)	0	0	0	\$0
12. Other Structures** (outbuildings, bridges, etc.) (FPU 900-999)	0	0	0	\$0
<b>13. TOTALS FOR STRUCTURE FIRES (SHOULD BE SUM OF LINES 5 THROUGH 12)</b>	<b>2</b>	<b>0</b>	<b>0</b>	<b>\$17,500</b>
<b>B. OTHER FIRE AND INCIDENTS</b>				
14a. Fires in Highway Vehicles (autos, trucks, buses, etc.) (IT 131-132, 136-137)	7	0	0	\$0
14b. Fires in Other Vehicles (planes, trains, ships, construction or farm vehicles, etc.) (IT 130, 133-135, 138)	2	0	0	\$0
15. Fires outside of Structures with Value Involved, but Not Vehicles (outside storage, crops, timber, etc.) (IT 140, 141, 161, 162, 164, 170-173)	2	0	0	\$2,000
16. Fires in Brush, Grass, Wildland (excluding crops and timber) with no value involved. (IT 142-143)	2	0	0	
17. Fires in Rubbish, Including Dumpsters (outside of structures), with no value involved. (IT 150-155)	0	0	0	
18. All Other Fires. (IT 100, 160, 163)	3	0	0	\$0
<b>19. TOTAL FOR FIRES (SHOULD BE SUM OF LINES 13 THROUGH 18)</b>	<b>18</b>	<b>0</b>	<b>0</b>	<b>\$19,500</b>
20. Rescue, Emergency Medical Responses (ambulance, EMS, rescue) (IT 300-381)	159			
21. False Alarm Responses (malicious or unintentional false calls, system malfunctions, bomb scares) (IT 700-746)	29			
22. Mutual Aid or Assistance Responses Given	6			
23a. Hazardous Materials Responses (spills, leaks, etc.) (IT 410-431)	6			
23b. Other Hazardous Conditions (arcing wires, bomb removal, power line down, etc.) (IT 440-482, 400)	13			
24. All Other Responses (smoke scares, lock-outs, animal rescues, etc.) (IT 200-251, 500-699, 800-911)	38			
<b>25. TOTAL FOR ALL INCIDENTS (SHOULD BE SUM OF LINES 19 THROUGH 24)</b>	<b>269</b>			

Based on what is reported in lines 5 and 13 for number of fire above, please report separately:

*Confined fires (e.g., cooking fires confined to cooking vessel, or chimney fire that did not spread beyond chimney, or confined trash fires) IT 113 - 118), and Nonconfined fires (IT 110 - 112, 120 - 123).*

	Number of Confined Fires	Number of Nonconfined Fires
5. Residential Fires (line 5 above)	0	2
13. Structure Fires (line 13 above)	0	2

### BREAKDOWN OF FALSE ALARM RESPONSES

Type of Fire Alarm	Number of Incidents
1. Malicious, Mischievous False Call (IT 710-715)	0
2. System Malfunction (IT 700-739)	7
3. Unintentional (tripping on interior device accidentally etc.) (IT 740-749)	13
4. Other False Alarms (bomb scares, etc.) (IT 721, 700)	9

Attach. #2

**Key Largo Volunteer Fire Department,**

Fire Department: 38032  
 Companies: All  
 Date Range: From 05/28/2013 to 12/31/2013  
 Box/Zone/ Code: All  
 Situation Found: All  
 Exclude Mutual Aids: No  
 Exclude Exposures: No

**Average Attendance at NFIRS Incidents**

Attendance		Totals
0 - 4		196
5 - 9		69
10 - 14		5
15 - 19		0
20 - 24		0
25 - 29		0
30 - 34		0
35 - 39		0
40 - 44		0
45 - 49		0
50 - 54		0
55 - 59		0
60 - 64		0
65 - 69		0
70 - 74		0
75 - 79		0
80 - 84		0
85 - 89		0
90 - 94		0
> 95		0

Lowest Attendance: 1  
 Incident Number: 2013-000075  
 Highest Attendance: 13  
 Incident Number: 2013-000272  
 Average Response: 4.04

Attach. #3



ATTACH #4 10 of 4





АТЛАСИ #4  
2014



KEY LARGO FIRE RESCUE

STATION NO.

24

TAN24KER

ATTACH #14  
30 of 44



ATTACH # 4  
4 of 4

# KEY LARGO FIRE RESCUE AND EMERGENCY MEDICAL SERVICES DISTRICT



## FY12/13 Adopted Budget

The KLFR&EMS District Mission is to provide **exceptional** fire protection and emergency medical services **efficiently and cost-effectively** without compromising the health or safety of residents or personnel.

KLFR&EMS District, P. O. Box 371023, Key Largo, FL 33037-1023

**KEY LARGO FIRE RESCUE AND EMS DISTRICT  
FY 2012-2013  
BUDGET DETAILS - FIRE DEPARTMENT**

9/25/2012

	<b>Department:</b>	<b>1250</b>	<b>Key Largo Fire &amp; Rescue</b>
	<b>Exp Transaction Code</b>	<b>522</b>	<b>(except as indicated below)</b>
<b>Acct #</b>	<b>Computation / Explanation</b>		<b>FY 12-13 Adopted Budget</b>
120	Regular Salaries & Wages:		
	Office Manager		57,720
	Firefighter II/EMT (1)		46,042
	Firefighter II/EMT (1)		45,391
	Firefighter II/EMT (1)		42,745
	1 Supervisor Firefighter II/ Driver Operator per 24hr x 365		85,410
	<i>Total Regular Salaries &amp; Wages</i>		<i>277,308</i>
121	Volunteer Pay:		
.01	Volunteer Chief's Reimbursement		24,000
.02	Volunteer Assistant Chief's Reimbursement		21,600
.03	3 Vol. F/F @ \$120 / 24 hr. day x 365 days x 2 stations = 262,800, if all slots are filled, however, based on previous experience this line item has been decrease to be in line with actual results		241,322
.03	2 Vol. F/F Home Shift Drivers (2 per station) @ \$30 / 12 hr. shift x 365 days		21,900
.03	Base Pay for Vols., Stipends, Responders, Special Details **		22,000
	<i>Total Volunteer Pay</i>		<i>330,822</i>
140	Overtime wages		6,080
210	Employer Payroll Taxes @ 7.65% of Full Time Wages and Volunteer Pay		46,987
220	Retirement Plan		10,000
230	Life & Health Insurance		
	Medical/Dental/Vision/Life Insurance for (4) Full Time Employees (\$500 per month each)		24,325
240	Worker's Compensation		26,560
250	Unemployment Tax		16,500

BUD - 2013/14

2017

**KEY LARGO FIRE RESCUE AND EMS DISTRICT  
FY 2012-2013  
BUDGET DETAILS - FIRE DEPARTMENT**

9/25/2012

	<b>Department:</b>	<b>1250</b>	<b>Key Largo Fire &amp; Rescue</b>
	<b>Exp Transaction Code</b>	<b>522</b>	<b>(except as indicated below)</b>
<b>Acct #</b>	<b>Computation / Explanation</b>		<b>FY 12-13 Adopted Budget</b>
312	Professional Services:		
	Firefighter Annual Physicals (\$400*50 F/F's includes TB test & Drug Testing)		20,000
	Background Checks, drug testing		1,000
	<i>Total Professional Services</i>		21,000
314	Legal Services - Non-Litigation - Reasonable Stipend		1
320	Accounting Fees (*note: Corporation pays an additional fee for accounting not reflected here.)		13,000
400	Travel & Per Diem - Training, Seminars, Meetings		10,000
401	Vehicle Reimbursement: Volunteer Chief's Command Vehicle		7,800
410	Phones, Television & Internet (Station Phones, Cell Phones, Air Cards)		
.01	Station Phones, Equipment lease and DSL- North & So. Stations		12,900
.02	Cell Phone and Air Card Svcs - (8) Phones & (2) PCS card		7,691
.03	Television Service		2,500
	<i>Total Phones</i>		23,091
412	Postage & Freight		500
430	Utilities		
.01	Electric		33,025
.02	Water (additional \$5,480 for sewer fees)		17,000
.03	Fire Hydrant Maintenance (120 Hydrants @ \$ 50 per hydrant)		6,000
.04	Propane Gas		724
	<i>Total Utilities</i>		56,749
440	Rent & Leases:		
	Station 24 Copier/Scanner/Fax Lease:		7,540
	Annual Lease Payment - DEP Station 25 Property		300
	Red Alert Incident Reporting Program support and maintenance		495
	<i>Total Rent &amp; Leases</i>		8,335

**KEY LARGO FIRE RESCUE AND EMS DISTRICT  
FY 2012-2013  
BUDGET DETAILS - FIRE DEPARTMENT**

9/25/2012

	<b>Department:</b>	<b>1250</b>	<b>Key Largo Fire &amp; Rescue</b>
	<b>Exp Transaction Code</b>	<b>522</b>	<b>(except as indicated below)</b>
<b>Acct #</b>	<b>Computation / Explanation</b>		<b>FY 12-13 Adopted Budget</b>
450	Risk Management		
	Package (Property, General & Mgmt Liability, Portable Equipment)		40,030
	Auto		16,612
	Statutory AD&D		740
	Accident and Sickness		8,644
	Umbrella Policy		1,560
	Storage Tank Liability		1,456
	<i>Total Risk Management</i>		69,042
460	Repair & Maintenance: Equipment		
	Air Packs		6,500
	Tools & Equipment		3,500
	Ground Ladders inspection		2,400
	Hurst tools inspection and maintenance		5,100
	<i>Total R&amp;M Equipment</i>		17,500
461	Repair & Maintenance: Buildings & Grounds		10,500
	Generator Preventive Maintenance Program		2,000
	Diesel fuel tank inspections both stations		2,400
	Elevator Maintenance Plan		3,500
	<i>Total R&amp;M: Buildings</i>		18,400
462	Repair & Maintenance: Vehicles (includes oil & lube)		43,425
	Aerial Truck Inspecting and Testing		1,100
	<i>Total R&amp;M Vehicles</i>		44,525
470	Printing and Binding		500
490	General Departmental: General Office & Administrative Costs		
.04	Key Largo Wastewater District Assessments		3,924
.05	Other		1,700
.06	Computer / IT Services		2,500
.07	Payroll Processing Fees		700
	<i>Total General Departmental</i>		8,824

**KEY LARGO FIRE RESCUE AND EMS DISTRICT  
FY 2012-2013  
BUDGET DETAILS - FIRE DEPARTMENT**

9/25/2012

	<b>Department:</b>	<b>1250</b>	<b>Key Largo Fire &amp; Rescue</b>
	<b>Exp Transaction Code</b>	<b>522</b>	<b>(except as indicated below)</b>
<b>Acct #</b>	<b>Computation / Explanation</b>		<b>FY 12-13 Adopted Budget</b>
491	Training - Instructor Fees, Education, Student Text and Fire Prevention		
.01	In-house training (Instructor Fees)		10,000
.02	WET Team Training		1,600
.03	Fire Prevention (KLVFD Only)		4,900
.04	Seminar Fees & Education & Text Books		5,500
.05	KAPLAN online education (50 firefighters @ \$60 per student)		3,000
	<i>Total Training</i>		<b>25,000</b>
510	Office Supplies		4,725
520	Operating Supplies		
.01	Fire Ground Safety		6,300
.02	Daily Operating/Maintenance Supplies		6,628
.03	Medical Supplies & Equipment		4,000
.04	Command Vehicle Computer Software		2,200
.05	Station Cleaning/Housekeeping Supplies		7,144
.06	Firefighting Gear (10 sets of Bunker Gear)		26,386
.07	Clothing, Apparel		8,200
.08	Firefighting Foam or suppression agent		9,500
	<i>Total Operating Supplies</i>		<b>70,358</b>
521	Fuel: Gasoline		7,670
522	Fuel: Diesel		22,878
540	Dues, Subscriptions and Publications		2,000
630	Capital Outlay: Infrastructure Improvements		
	10 Fire Hydrants (\$6,050 per hydrant + 5% admin fee)		63,525
	<i>Total Capital Outlay: Infrastructure Improvements</i>		<b>63,525</b>
640	Capital Outlay: Equipment - Hurst Tool		5,000



**KEY LARGO FIRE RESCUE AND EMS DISTRICT  
FY 2012-2013  
BUDGET DETAILS - FIRE DEPARTMENT**

9/25/2012

	<b>Department:</b>	<b>1250</b>	<b>Key Largo Fire &amp; Rescue</b>	
	<b>Exp Transaction Code</b>	<b>522</b>	<b>(except as indicated below)</b>	
<b>Acct #</b>	<b>Computation / Explanation</b>			<b>FY 12-13 Adopted Budget</b>
641	Capital Outlay: Vehicles - Squad 24			
	Rescue Pumper - Squad 24			99,629
	Tanker Pumper			259,000
	Ladder			600,000
	<i>Total Capital Outlay: Vehicles</i>			<i>958,629</i>
642	Capital Outlay: Small Tools & Equipment			
	Various Hose, Tools, Equipment >\$1,000 but < \$ 2,500 per each item and a useful life of 1 year or more			2,500
			<b>Department Total</b>	<b>\$ 2,200,134</b>
			Total Operating Budget	1,170,480
			Total Capital Budget	1,029,654
			Total	2,200,134
** = Monthly - \$150 FFI, \$175 FFII, Stipends per responder \$30 per call or \$15 for responding but not working a fire				

BUD-2013/14

6 of 7

**KEY LARGO FIRE RESCUE AND EMS DISTRICT  
VEHICLE REPLACEMENT FUNDING ANALYSIS  
FY12-13**

Year	Beginning Balance	Contributions	Purchases & Other Distributions	Ending Balance	Vehicle to be Replaced
09/30/12	\$ 1,753,225	\$ 12,023	\$ (303,272)	\$ 1,461,976	pumper 75%
09/30/13	\$ 1,461,976	\$ -	\$ (1,158,629)	\$ 303,347	pumper 25%/Tanker/Ladder/ Transfer Out
09/30/14	\$ 303,347	\$ 125,000	\$ (270,000)	\$ 158,347	2 ambulances (new in 2002, 2003)
09/30/15	\$ 158,347	\$ 175,000	\$ -	\$ 333,347	
09/30/16	\$ 333,347	\$ 225,000	\$ -	\$ 558,347	
09/30/17	\$ 558,347	\$ 275,000	\$ -	\$ 833,347	
09/30/18	\$ 833,347	\$ 275,000	\$ (965,000)	\$ 143,347	engine 24, engine 25
09/30/19	\$ 143,347	\$ 250,000	\$ (360,000)	\$ 33,347	ambulance (new in 2008), Cascade
09/30/20	\$ 33,347	\$ 250,000	\$ -	\$ 283,347	
09/30/21	\$ 283,347	\$ 250,000	\$ -	\$ 533,347	
09/30/22	\$ 533,347	\$ 250,000	\$ (135,000)	\$ 648,347	ambulance (new in 2011)
09/30/23	\$ 648,347	\$ 250,000	\$ -	\$ 898,347	

Equipment/Vehicle Type	Dept	Make	Unit #	Year New	Service Life	Replace Year	Years to Replacement	Estimated Replacement Cost (updated for FY12/13 Budget)
Technical Rescue Pumper	Fire Rescue	Salsbury	SQUAD-24	1994		19	2013	399,000
Tanker/Pumper	Fire Rescue	Boardman	TANKER-24	1993		20	2013	265,000
80' Ladder / Pumper	Fire Rescue	E-One	LADDER-24	1988		26	2013	600,000
Class A Engine	Fire Rescue	Pierce	ENGINE-25	2001		17	2018	475,000
Class A Engine	Fire Rescue	Pierce	ENGINE-24	2001		17	2018	490,000
Cascade Air Fill & Lighting Truck	Fire Rescue	Ford-Pierce	AIR-24	2002		17	2019	225,000
Dive Rescue Van	Fire Rescue	EVI - International	WATER RESCUE-25	2009		15	2024	255,000
Type III Ambulance	EMS			2002		11	2013	135,000
Type III Ambulance	EMS			2003		11	2014	135,000
Type III Ambulance	EMS			2008		11	2019	135,000
Type III Ambulance	EMS	2009 Ford Chassis		2011		11	2022	135,000

p. 06 BUD-2013/14

BUD-2013/14 7 of 7